

# NCP OUTDOOR

## LumaDome Light Kit Installation for the ZipUP Underdeck® System

### Pre-Installation Notes

- **IMPORTANT:** Do not cut any wires. Any extra wire length can be coiled up.
- If using insulated wire staples to hold the wires in place, be sure not to pierce or crush the wires.
- Follow all instructions for the LumaDome light kit installation for the ZipUP Underdeck® System.
- The LumaDome light kit is engineered to be weatherproof. It is best to install on smooth surfaces to ensure tight, water-proof seal of the gaskets.

### Step 1

#### Prepare the Transformer and Wiring Harness

1.1 Follow the instructions provided for the 'Smart Transformer Control Instructions' to ensure proper installation.

1.2 Follow the instructions provided for the 'Wiring Harness and Splitters' to ensure proper installation.

1.3 Choose a proper spot for the power supply module. It can be hidden completely since it uses Bluetooth and Wi-Fi for connectivity.

### Step 2

#### Prepare the Light Layout

2.1 The LumaDome light kit for the ZipUP Underdeck® system includes all the components needed to illuminate a 12' x 12' area. To ensure even lighting, configure the spacing and arrangement of the lights as needed. For a 12' x 12' area, you can follow the layout shown.

2.2 Layout the lights beneath the project and plug in to ensure all connections are properly made.

**TIP:** When installing lights with the ZipUP Underdeck® system, space the fixtures between a minimum of 24" to 48" maximum depending on your preferred illumination. **36" is the recommended spacing.** Be mindful of the pitch rails' locations and adjust the fixture placement as needed to prevent the rails from interfering with the installation.

**NOTE:** The Smart Transformer can operate up to 50 low-voltage lights. For larger decks, additional light kits can be purchased to extend your layout.

### Step 3

#### Measure and Mark

3.1 Measure for each light placement from either the main structure wall or main beam and mark a point in the middle of the panel. Measure from the edge of the panel and mark the center point making an "X" for the center of the light.

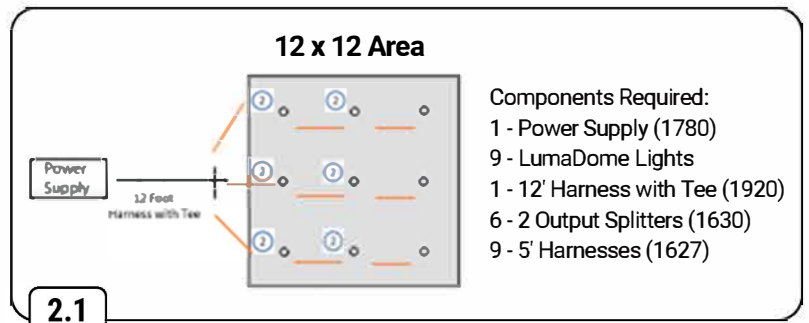
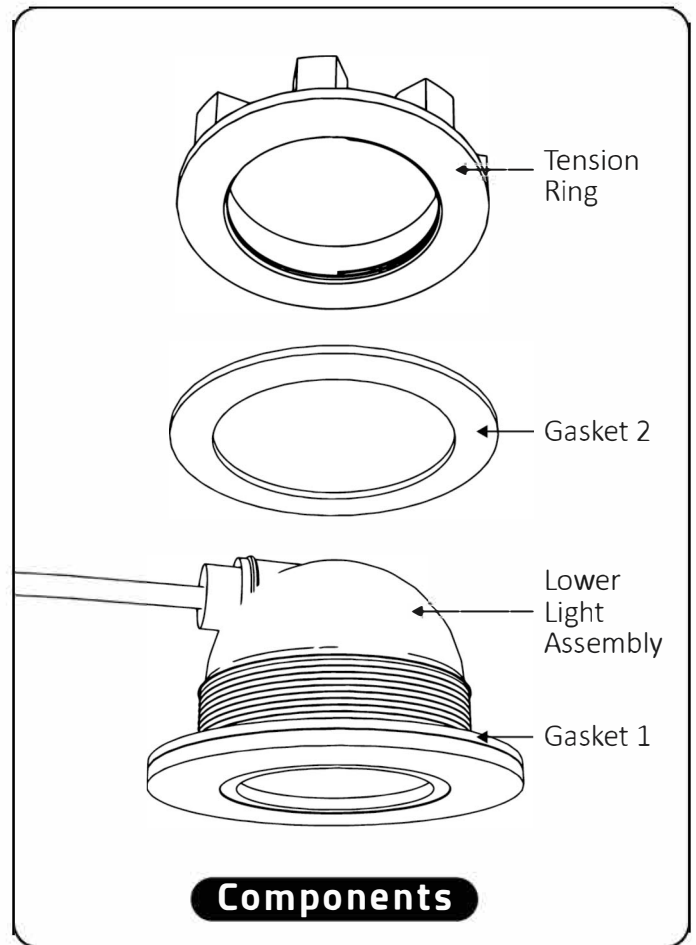

## Step 4

### Drill the Holes

4.1 At the "X" drill a **2.5" hole** using a drill and hole saw.

**TIP:** It works best to drill the alignment hole clockwise and once that's punched through then use the hole saw in reverse as it helps to stabilize the cut.

## Step 5

5.1 Disassemble the connections and begin the install. Starting at one end of the project pull down one side of the first panel that contains a light.

5.2 Feed the wiring of the light through the hole and be sure to put one of the gaskets on each side of the panel fishing the wiring of the light through one gasket along with the tension ring.

5.3 Push the light into the panel and hand tighten the tension ring until the gaskets are under pressure on both sides to resist leaking.

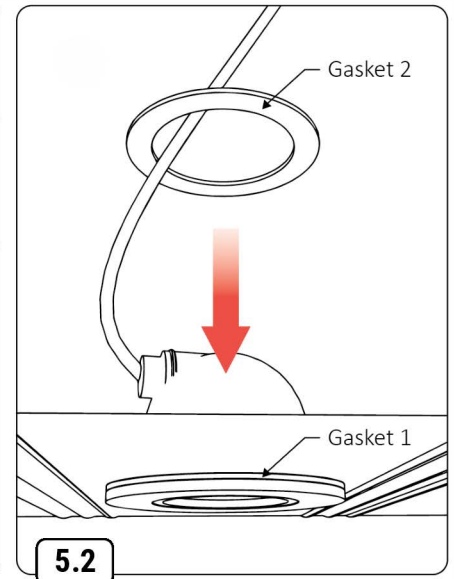
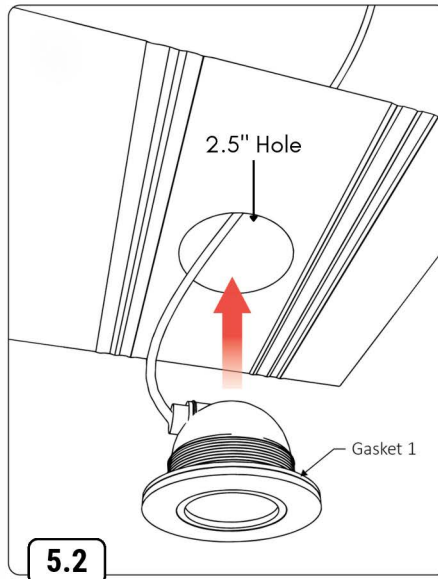

## Step 6

6.1 Fish the wiring and T's over the panels between the lights. At the next panel with lights pull one side of that panel down and repeat Step 5.

**NOTE:** it may be needed to pull other panels down in between the lights to help fish the wiring through.

6.2 Continue with Step 6 through the rest of the area installing and tightening all the lights into place.

## Step 7

7.1 Secure the power supply module into place near a 110V power source and connect. The power supply module can be secured to the wall, a ledger board, or even a joist. See **"Smart Transformer Instructions"** enclosed for proper installation.

7.2 Follow the enclosed instructions for connecting the power supply module for the LumaDome light kit.

7.3 Remember, you can control the lights using two apps: one works through your cell phone, and the other connects via Wi-Fi to devices like Alexa. See **'Smart Transformer Control Instructions'** enclosed for device setup.



5-YEAR WARRANTY

