

Solar Cap with Accessory Connect

Installation Notes

- Do not cut any wires. Any extra wire length can be coiled up.
- Replace battery when required with 14500 or 14505, 3.2V, 600 mAh, LiFePO4 (Lithium Phosphate) battery.

Step 1

Mount lighting fixture to post or rail

- 1.1 Use a template below to drill required holes for light accessory.
- 1.2 For Dome Light run connector through 3/8" hole and install back plate with two screws included. Place the dome/lens portion of the light over the back plate at a slight angle and rotate clockwise to lock in place.
- 1.3 For Stair/Side Light run connector through 3/8" hole and install lens with two screws included. Place either the full or half cover onto the lens by snapping into place.
- 1.4 For Under Rail light run connector through 3/8" hole and mount using the two screws included.

Step 2

Connect to Solar Cap

- 2.1 Run harness from light accessory to cap.
- 2.2 Remove pull tab in battery compartment.
- 2.3 Plug the male connector attached to the light to the female connector on bottom of cap. Press firmly until the connection is fully engaged.
- 2.4 If additional wire length is required the 2' harness extension can be used between cap and light. Using the 2 output splitter allows two lights to be powered by one post cap. (Maximum of 2 lights per solar cap is recommended).

Step 3

Finalize Installation

- 3.1 Apply a bead of clear exterior silicone caulking (not supplied) where the Post Cap Light will be installed onto the post or post wrap. Then place Post Cap Light onto the adhesive.

Components (Each sold separately)



Post Cap
(Style May Vary)



Dome Side Light

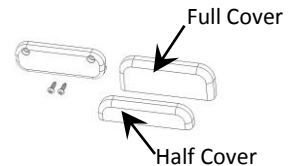

Stair/Side Light



Under Rail



2' Harness
Extension



2 Output Splitter

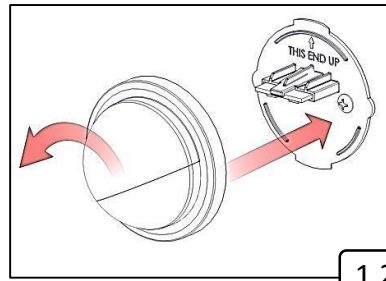

1.2

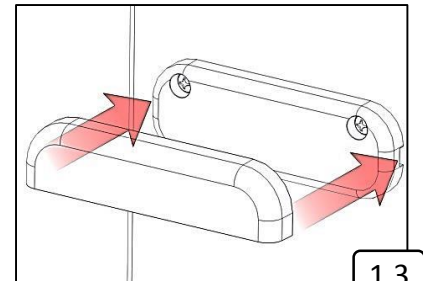

1.3

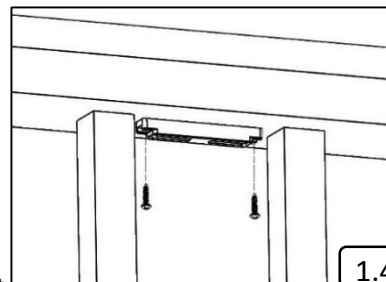

1.4

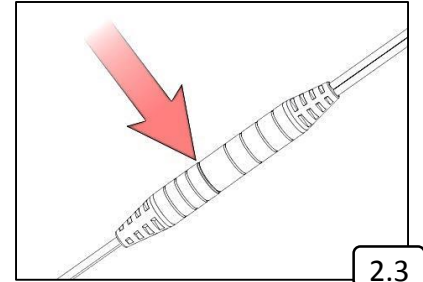

2.3

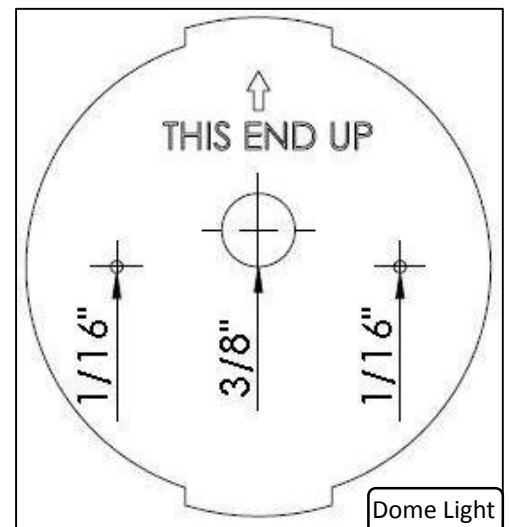
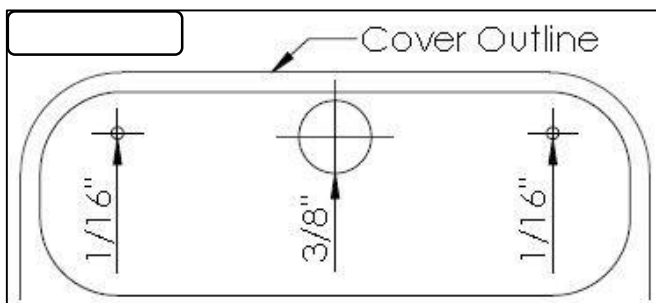
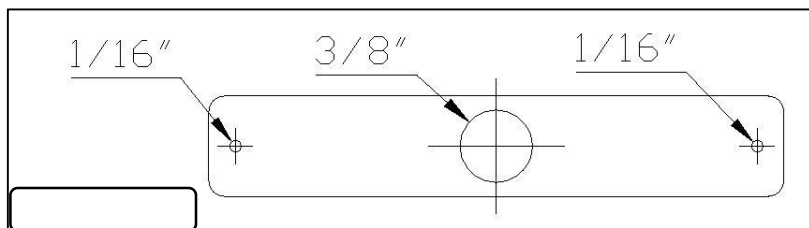

Solar Lighting Five Year Warranty

If within five (5) years from the date of purchase, this product fails due to a defect in material or workmanship, LMT Mercer Group Inc. will repair or replace it, at its sole option, free of charge. This warranty applies only to the original purchaser and is not transferable.

LMT Mercer Group Inc. will not be liable for incidental or consequential damages. Some states do not allow the exclusion or limitation of incidental or consequential damages, so the above limitation or exclusion may not apply to you.

This warranty is in lieu of all other express or implied warranties. All implied warranties, including the warranty of fitness for a particular purpose, are hereby modified to exist only as contained in this limited warranty, and shall be of the same duration as the warranty period stated above. Some states do not allow limitations on the duration of an implied warranty, so the above limitation may not apply to you.

The warranty does not apply to: (a) damage caused by accident, abuse, in handling, and/or dropping; (b) acts of God; (c) units which have been subject to unauthorized repair, opened, taken apart or otherwise modified; (d) units not used in accordance with directions; (e) units that have been submerged in water; (f) damages exceeding the cost of the product; (g) batteries; (h) the finish on any portion of the product, such as surface scratches and/or weathering, as this is considered normal wear and tear. Some states do not allow a limitation of damages so the foregoing limitation may not apply to you. This warranty gives you specific legal rights and you may also have other rights, which vary from state to state.

Warranty service is available by mailing postage prepaid to the authorized service station listed below. Please be sure to wrap the product securely when mailing to avoid shipping damage. This warranty is made by:

LMT Mercer Group Inc. c/o Customer Service
690 Puritan Ave. Lawrenceville, NJ 08648
888-570-5252